

## GARDU MENARA



**PT. SYMPHOS ELECTRIC**

Jl. Raya Agarindo No.10, Kel. Bunder Kec. Cikupa, Tangerang - Banten 15710

Phone : +62 21 5971 2088, 5971 2089, 5971 2039 - Fax. : +62 21 5971 2039

Email : [marketing@symphos-weltraf.com](mailto:marketing@symphos-weltraf.com) | Instagram : @symphosweltraf

[www.symphoselectric.com](http://www.symphoselectric.com)

**MADE IN INDONESIA**

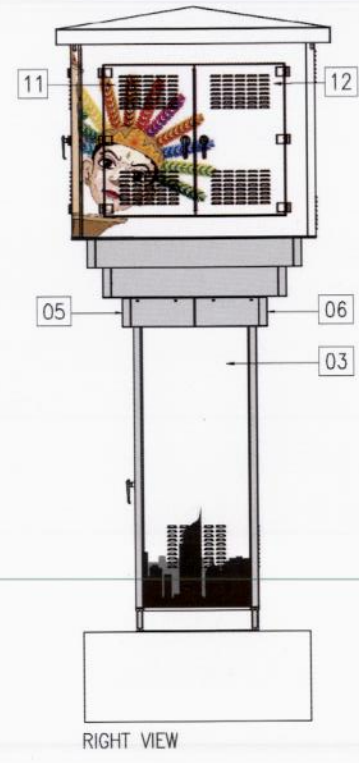
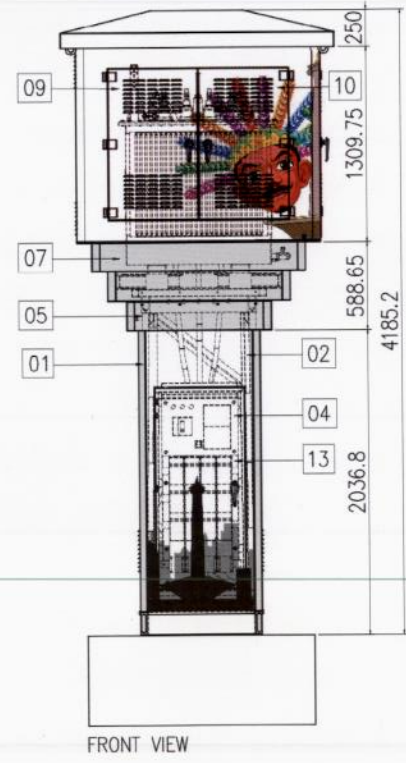
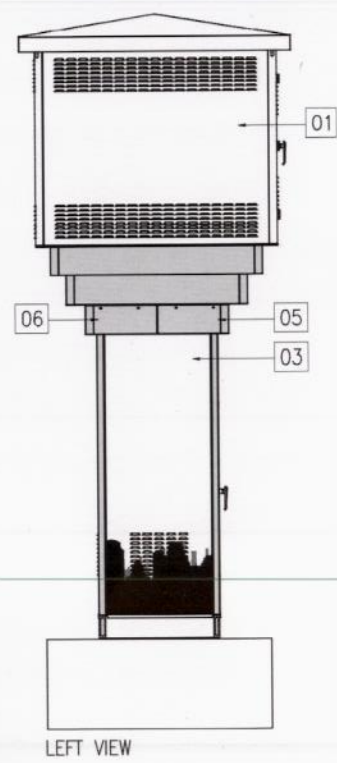
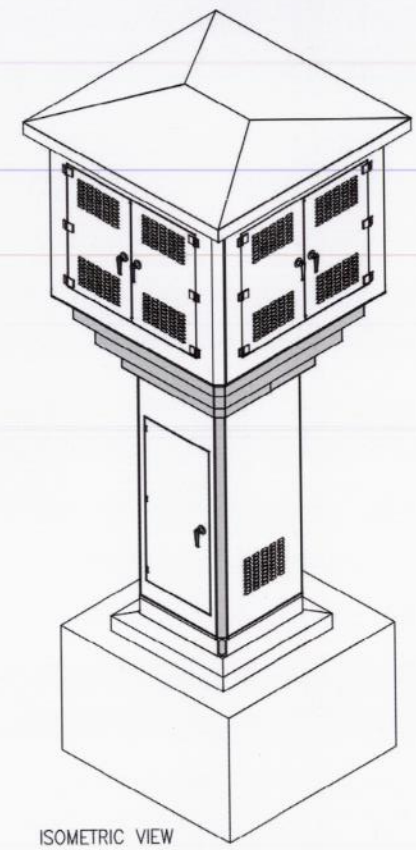
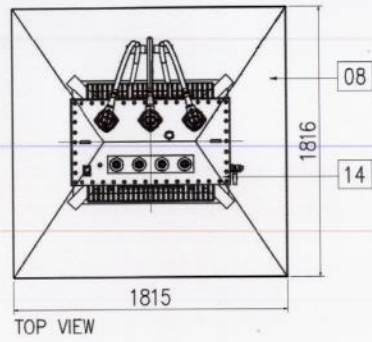

NO.	NAMA PARTS	QTY
14	TRANSFORMATOR	1
13	PHB-TR	1
12	PINTU TRAFU KANAN SAMPING	1
11	PINTU TRAFU KIRI SAMPING	1
10	PINTU TRAFU KANAN DEPAN	1
09	PINTU TRAFU KIRI DEPAN	1
08	ASSEMBLY HOUSING	1
07	ASSEMBLY TRANSFORMER HOLDER	1
06	PART HOUSING COVER 2	1
05	PART HOUSING COVER 1	1
04	ASSEMBLY PINTU BAWAH	1
03	ASSEMBLY WELD COVER 2	3
02	ASSEMBLY WELD COVER 1	1
01	ASSEMBLY KOMPARTEMEN TIANG	1

REV	ITEM	DATE	NAME	DATE	NAME
			DESIGNED		GTR
			DRAWN		PYN
			CHECKED		PYN
			APPROVED		STA

CUSTOMER :

DRAWING CODE : GGM0250R2-4XXX

**WELTRAF**  
transformer  
PT. SYMPHOS ELECTRIC

DRAWING TITLE : ASSEMBLY KOMPARTEMEN TIANG

ORDER : XX/XX  
1 UNIT

PAGE : E-01

SCALE : 1:20

TOLERANSI ± 3 % \*TOLERANSI ± 5 mm